

DESCH Revox[®] Gearbox - All in One

„The“ drive solution for mobile crushers

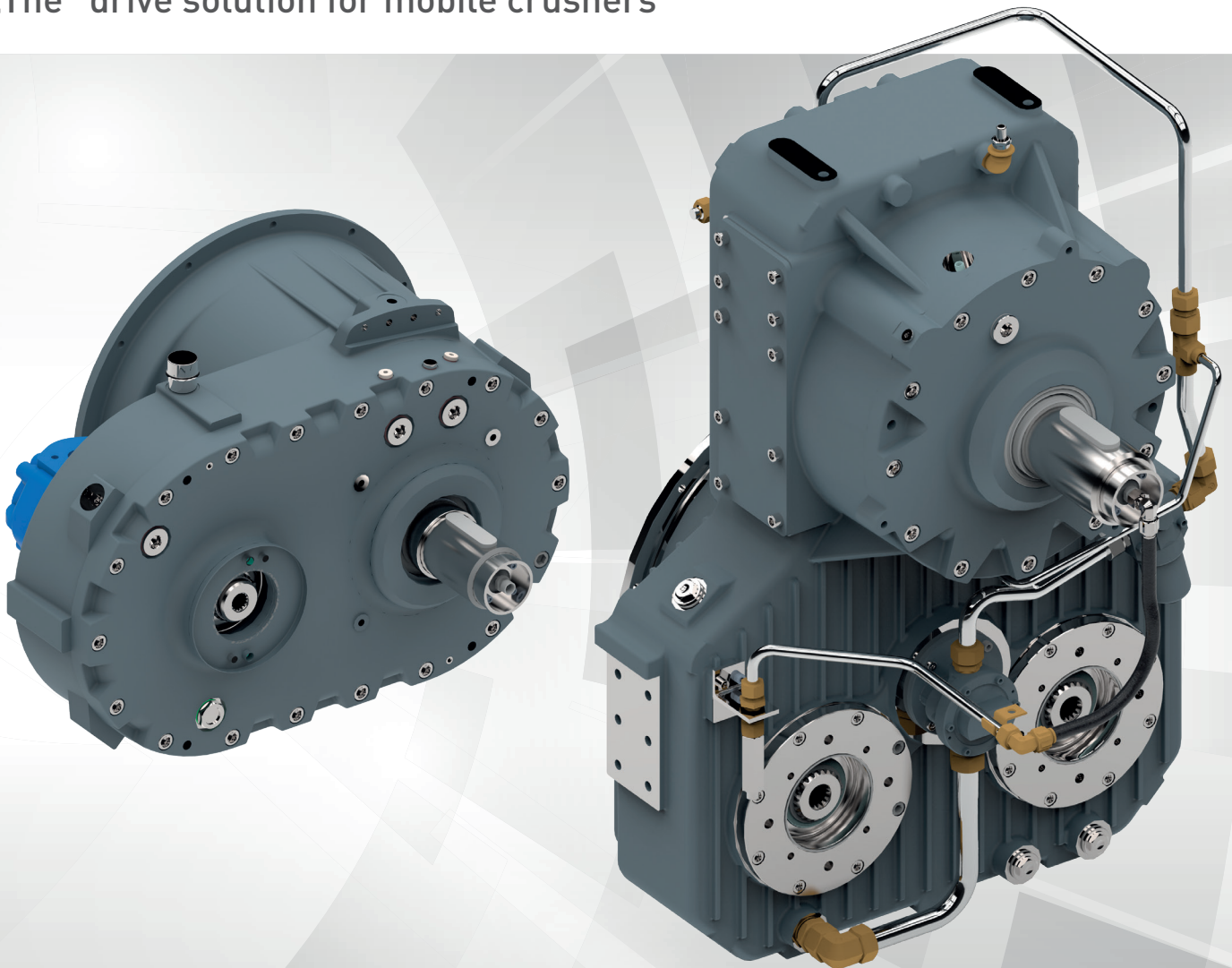

DESCH Revox[®] Gearbox

Rising costs for energy and waste disposal, as well as increasing raw material shortages, are calling for innovative, environmentally friendly system solutions. Here, the drive train is of particular significance.

Thanks to the new **Revox[®]** drive concept, a gear coupling unit, it has become possible to combine an energy-saving direct drive with the versatility of hydraulic drive technology. The core of this drive system is a power-split drive train.

A hydraulic motor mounted either takes care of the starting process to ensure gentle, safe running-up of the crusher rotor. Highly sensitive electronic control systems can be dispensed with.

The option of reversibility is particularly important in jaw cutters. For removing blockages in the crushing jaw as well as with various materials (such as bitumen), it is possible to operate the machine in reverse with the help of a hydraulic motor - and with full cutting torque.

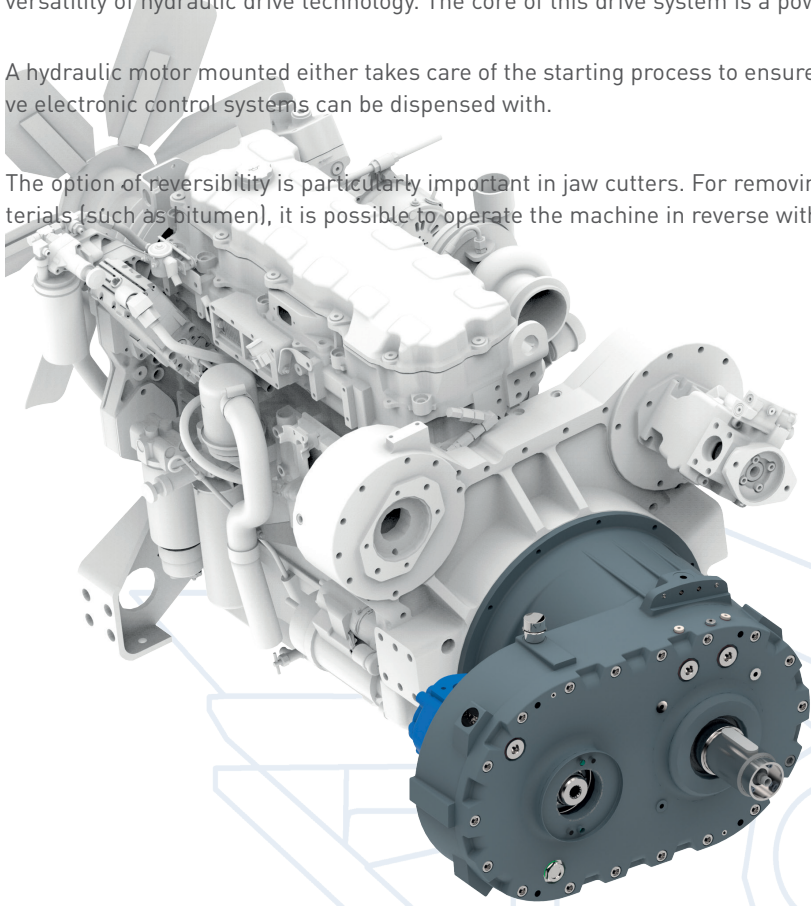

ADVANTAGES Revox[®] S - Gearbox

- Hydraulic soft start
- Almost wear-free clutch operation
- Mechanical direct drive
- Energy-efficient by a disconnectable start-up motor as standard
- Robust design by standard parts
- Wet operating clutch

Technical data Revox[®] S

Max. power:	280 kW
Max. torque:	1800 Nm
Idle speed:	800 rpm
Max. speed:	2100 rpm
Ratio hydraulic pump:	i = 1,31
Clutch pressure:	40 bar

The new **Revox[®] S** compose a standard gear unit to start-up high rotatory inertia in particular for crushing operation.

Drive systems for constant speed engines are subject to high requirements during acceleration of the rotor.

Due to the high engagement speed of the clutch an increase of the performed friction work raised which lead to a high wear.

The **Revox[®] S** dispose of a hydraulic soft start system which handle the risk of high friction work by a soft start-up device which means of a hydraulic gear motor. This enables a wear reduced start-up procedure even at high engine speeds up to 1500 rpm.

During operating mode a robust wet clutch transmit the engine torque. The mechanical direct drive system lead to a energy-efficient drive solution.

The **Revox[®] S** is provided with a SAE B-B hydraulic pump connection by default.

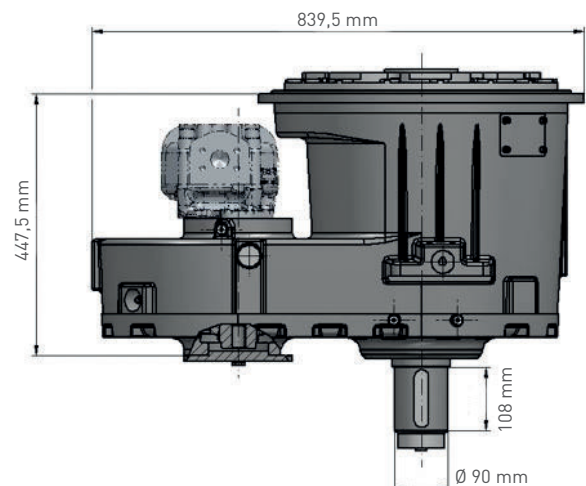

„The“ drive solution for mobile crushers

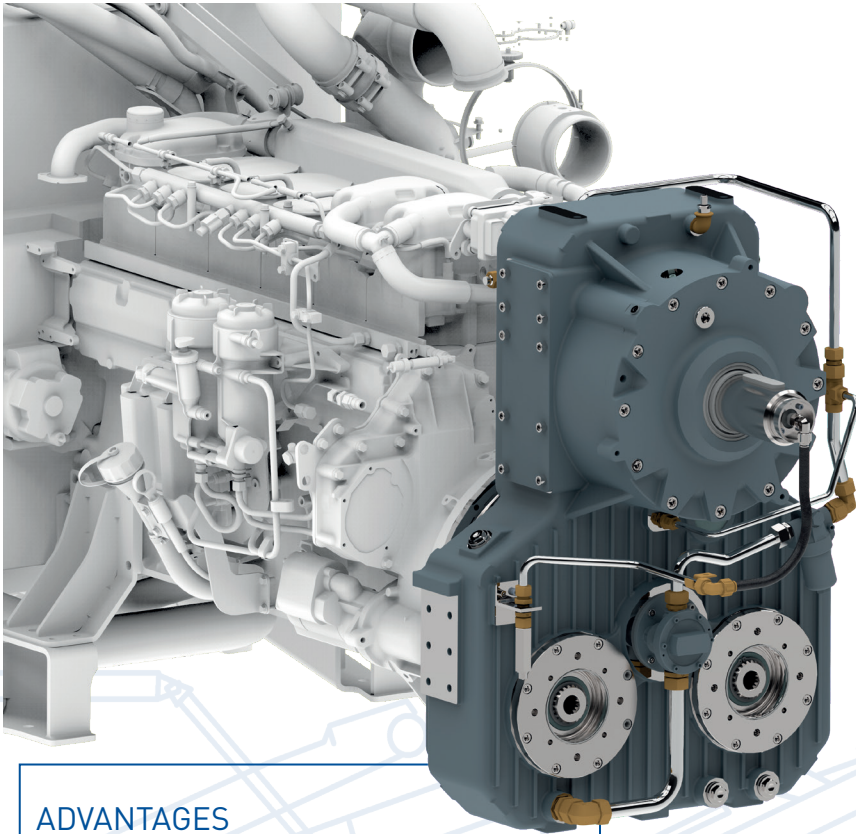

ADVANTAGES Revox® - Gearbox

- Hydraulic soft start
- Almost wear-free clutch operation
- Mechanical direct drive
- Reverse drive option by max. torque
- Disconnectable start-up motor as an option
- Robust design by standard parts
- High availability
- Flexible application
- Wet operating clutch

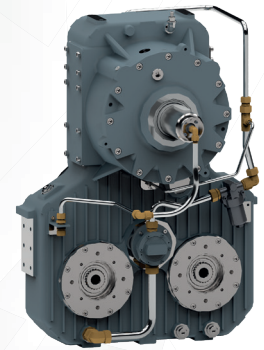
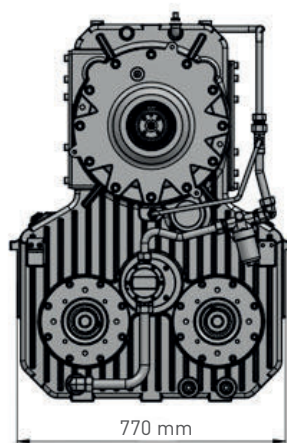
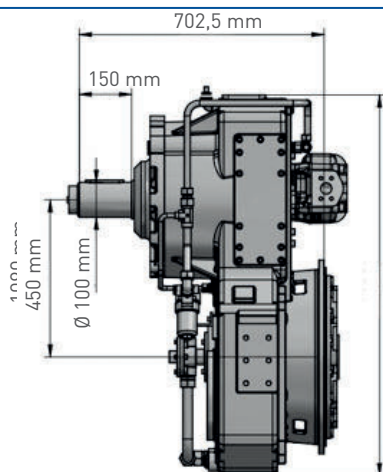

Revox® - standard

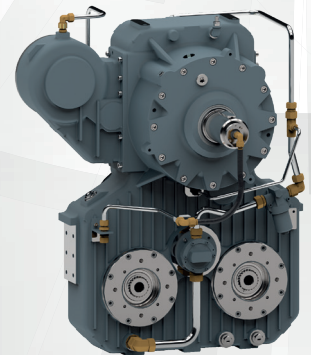

Revox® - with third pump connection

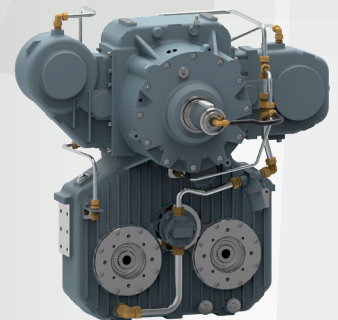

Revox® - with reverse drive

Technical data Revox®

Max. Power:	400 kW
Max. torque:	2500 Nm
Idle speed:	800 rpm
Max. speed:	2100 rpm
Ratio output:	i = 1,41
Ratio hydraulic pump:	i = 0,78
Operating pressure:	200 bar
Clutch pressure:	40 bar

Contact

Nidec DESCH Antriebstechnik GmbH & Co. KG
Postfach / Postbox 1440
59753 Arnsberg/Germany
Kleinbahnstraße 21
59759 Arnsberg/Germany
T +49 2932 300 0
info@desch.com
www.desch.com

